

6.3.3 WEIGHING

- Once the aircraft has been leveled, record the weight on the main wheels and the tailwheel.

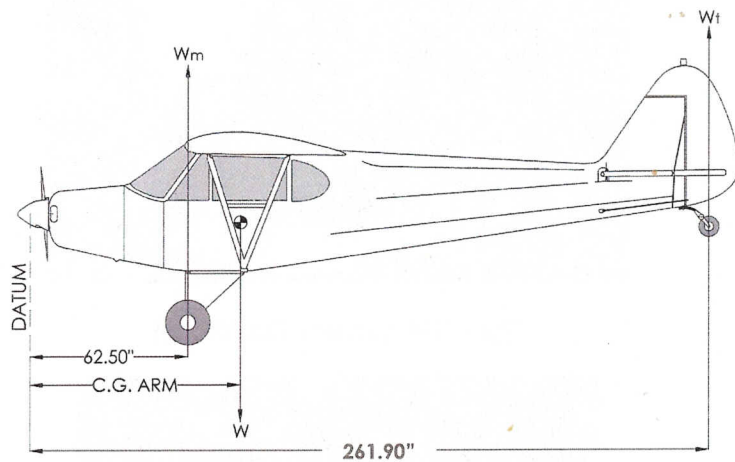

Figure 6-3 Aircraft Geometry

$$CG\ Arm = \frac{(W_m \times 62.50) + (W_t \times 261.90)}{W}$$

Where:

- CG Arm* = Distance from the datum to the center of gravity (in inches)
W = Total weight of the aircraft
W_m = Sum of the weight on both main wheels
W_t = Weight on the tailwheel

6.4 WEIGHT AND BALANCE DATA AND RECORD

Table 6-1 shows the following information at the time when the aircraft was licensed at the factory:

- Basic empty Weight
- Center of Gravity
- Useful Load

MODEL CC11-100

Aircraft serial number: CC11-00051
 Registration number: N240CC
 Date: May 23, 2008

Basic empty weight (lbs)	Arm (inches)	Moment (in·lbs)
889.2	72.57	64,532.28

Table 6-1 Basic empty weight

Useful load = Maximum takeoff weight- Basic empty weight
 = 1320 - 889.2
 = 430.8 lbs

This basic empty weight, CG, and useful load are for the CC11-100 as it was licensed at the factory. Please refer to the appropriate aircraft records to determine the latest information, as the aircraft may have been altered.

CC11-100		SERIAL NUMBER <u>CC11-00051</u>		REGISTRATION NUMBER <u>N240CC</u>			PAGE NUMBER _____	
Date	Item No.	Description of Article or Modification	Added (+) Removed (-)	Weight Change			Running Basic Empty Weight	
				Wt (lb.)	Arm (ins.)	Moment/100	Wt (lb.)	Moment/100
	1	McCauley Metal Propeller, 41 Pitch						
	2	Deluxe VFR Instrument Panel						
	3	PM 1200 Intercom						
	4	Artex Model ME 406 ELT						
05/23/08	5	Halon Fire Extinguisher	-	1.2	64.0	-76.8		
	6	Lighting Package w/ Strobes						
	7	Premium Interior						
	8	8:50 x 6 Tires						
	9	ABW 3200 Tail Wheel						
	10	AOSS Gear						
05/23/08	11	Spin-On Oil Filter and Adapter	+	1.5	26.0	39.00		
05/23/08	12	AmSafe Harness System – Front	+	3.0	83.0	249.00		
05/23/08	13	AmSafe Harness System – Rear	+	3.9	110.0	429.00		
	14							
	15							
	16							
	17							
	18							
	19							

Table 6-2 Weight and Balance Record